



Ventiloconvector	Type	CFK015.0			Type	Ventilo-convecteur
			Cassette			
Verwarmen waterregime 35/30°C	maximumsnelheid	kW	2,5	kW	vitesse maximum	Chauffer regime 35/30°C
	gemiddelde snelheid	kW	1,97	kW	vitesse moyenne	
	laagste snelheid	kW	1,6	kW	vitesse minimum	
Verwarmen waterregime 55/50°C	maximumsnelheid	kW	7,07	kW	vitesse maximum	Chauffer regime 55/50°C
	gemiddelde snelheid	kW	5,59	kW	vitesse moyenne	
	laagste snelheid	kW	4,55	kW	vitesse minimum	
Koelen bij waterregime 7/12°C	maximumsnelheid	kW	4,20	kW	vitesse maximum	Refroidir regime 7/12°C
	gemiddelde snelheid	kW	3,48	kW	vitesse moyenne	
	laagste snelheid	kW	3,01	kW	vitesse minimum	
Koelen bij waterregime 18/22°C	maximumsnelheid	kW	1,21	kW	vitesse maximum	Refroidir regime 18/22°C
	gemiddelde snelheid	kW	1,02	kW	vitesse moyenne	
	laagste snelheid	kW	0,87	kW	vitesse minimum	
Luchtdebieten	maximumsnelheid	m³/h	781	m³/h	vitesse maximum	Débit d'air
	gemiddelde snelheid	m³/h	611	m³/h	vitesse moyenne	
	laagste snelheid	m³/h	494	m³/h	vitesse minimum	
Waterdebiet (55/50°C)	maximumsnelheid	l/h	1230	l/h	vitesse maximum	Débit d'eau (55/50°C)
	gemiddelde snelheid	l/h	970	l/h	vitesse moyenne	
	laagste snelheid	l/h	790	l/h	vitesse minimum	
Geluidsvermogen	maximumsnelheid	dB(A)	64	dB(A)	vitesse maximum	Puissance sonore
	gemiddelde snelheid	dB(A)	55	dB(A)	vitesse moyenne	
	laagste snelheid	dB(A)	51	dB(A)	vitesse minimum	
Geluidsdruk op 1,5m	maximumsnelheid	dB(A)	43	dB(A)	vitesse maximum	Niveau sonore à 1,5m
	gemiddelde snelheid	dB(A)	38	dB(A)	vitesse moyenne	
	laagste snelheid	dB(A)	32	dB(A)	vitesse minimum	
Ventilatorverbruik	maximumsnelheid	W	43	W	vitesse maximum	Consommation ventilateur
	gemiddelde snelheid	W	28	W	vitesse moyenne	
	laagste snelheid	W	21	W	vitesse minimum	
Elektrische installatie	voeding	V	230/1F	V	alimentation	Installation électrique
	stroom max	A	0,36	A	courant (max)	
	Stopcontact voorzien		Nee/Non		prévoir une prise	
Technische gegevens	ventilator		rad		ventilateur	Installation technique
	aantal ventilatoren		1		nombre de ventilateurs	
	type		DC		type	
	gewicht	kg	16,5	kg	poids	
	afmetingen (lengte-breedte-hoogte)	mm	575 x 575 x 261	mm	dimensions (profondeur-largeur-hauteur)	
	waterinhoud	l	1,020	l	contenu d'eau	
	waterzijdig drukverlies	kPa		kPa	résistance pression	
	buitendiameter condensafvoer	mm	25	mm	diamètre évacuation condens	
	condenspomp		Incl		pompe de condens	
	systeem		2-pijps / 2 pipes		système	
	hydraulische aansluitingsdiameter		G 3/4"		diamètre hydraulique	
	beschermingsgraad		IPX0		classe de protection	
	kleur (omkasting-rooster)	RAL	9003	RAL	couleur	
	3-wegklep 3/4"		Optie/Option		vanne à 3 voies	
condenspan voor 3-wegventiel		Optie/Option		bac à condensation pour valve à 3 voies		
Regeling	infraroodbediening		Incl.		commande infrarouge	Réglage
	muurbediening KJR90X		Optie/Option		réglage de température KJR90X	
	Modbus connectie		Incl.		connection Modbus	
	Ventilatorsturing 0-10V		Optie/Option		réglage de ventilateur 0-10V	
	Potentiaalvrij contact on/off		Optie/Option		contact sec on/off	



Infrared standard control

Features:

- Backlit

Functions:

- On/Off
- Operation selection: Auto, Heating, Cooling, Dehumidification, Ventilation
- Set the fan speed (MIN - MED - MAX or AUTO)
- Temperature setting (temperature range selectable: 17~30°C)
- Timer setting
- Setting of deflectors position (swing)



OPTION: KJR90X - Electronic room control for wall installation

KJR90 LCD "touch-key" wall-mounted control.

Functions:

- On/Off
- Operation selection: Auto, Heating, Cooling, Dehumidification, Ventilation
- Temperature setting (temperature range selectable: 17~30°C)
- Set the fan speed (MIN - MED - MAX or AUTO)
- Timer setting
- Setting of deflectors position (swing)

Many additional functions such as:

- ECO mode
- Controller keypad lock
- Timed remainder air filter cleaning

The controller can be easily connected to the internal unit display by means of a connecting cable.

The control can be installed up to a max. distance of 15mt.

16026200A26124

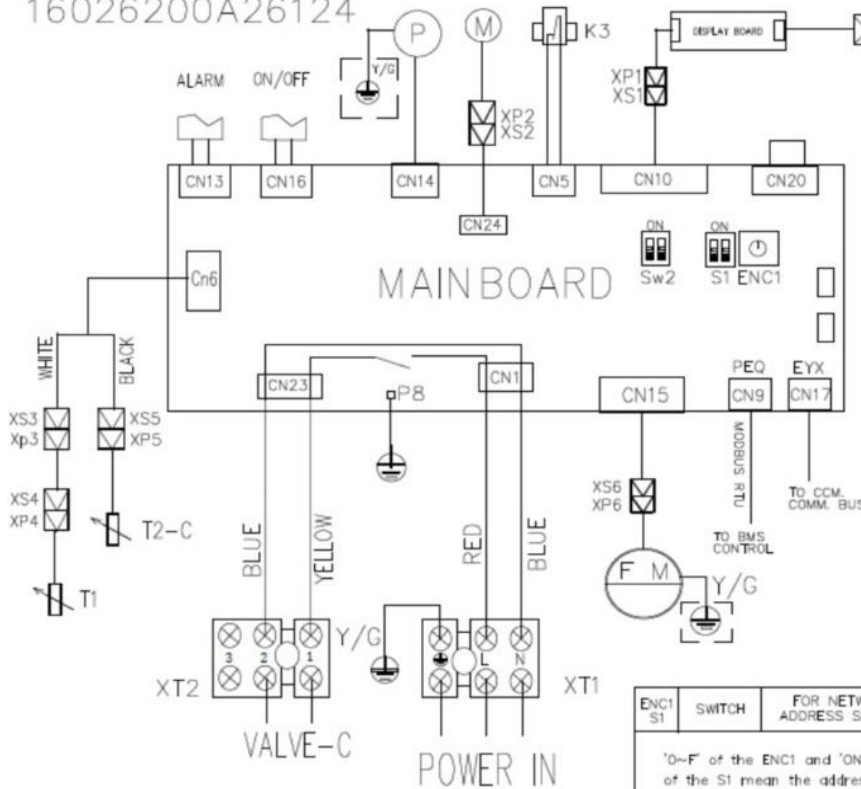

WIRING DIAGRAM

CODE	PART NAME
XT1-2	3-WAY TERMINAL
CN1-22,P1-8	P.C BOARD SOCKETS
SW2,S1,ENC1	SWITCH
F M	INDOOR FAN MOTOR
K3	WATER LEVEL SWITCH
M	SWING MOTOR
P	PUMP
T1	ROOM TEMPERATURE
T2-C	PIPE TEMPERATURE
XP1-6	CONNECTORS
XS1-6	CONNECTORS

MODEL	DIP SW2
FP-51KBM	
FP-68KBM	
FP-85KBM	

ENC1 SWITCH FOR NETWORK ADDRESS SETTING
 '0~F' of the ENC1 and 'ON/OFF' of the S1 mean the addresses of the different units, respectively.

NOTE:
 Alarm port: strong signal when a alarm output ;
 ON / OFF port: when closed, shut down; disconnect perform power-down memory function.

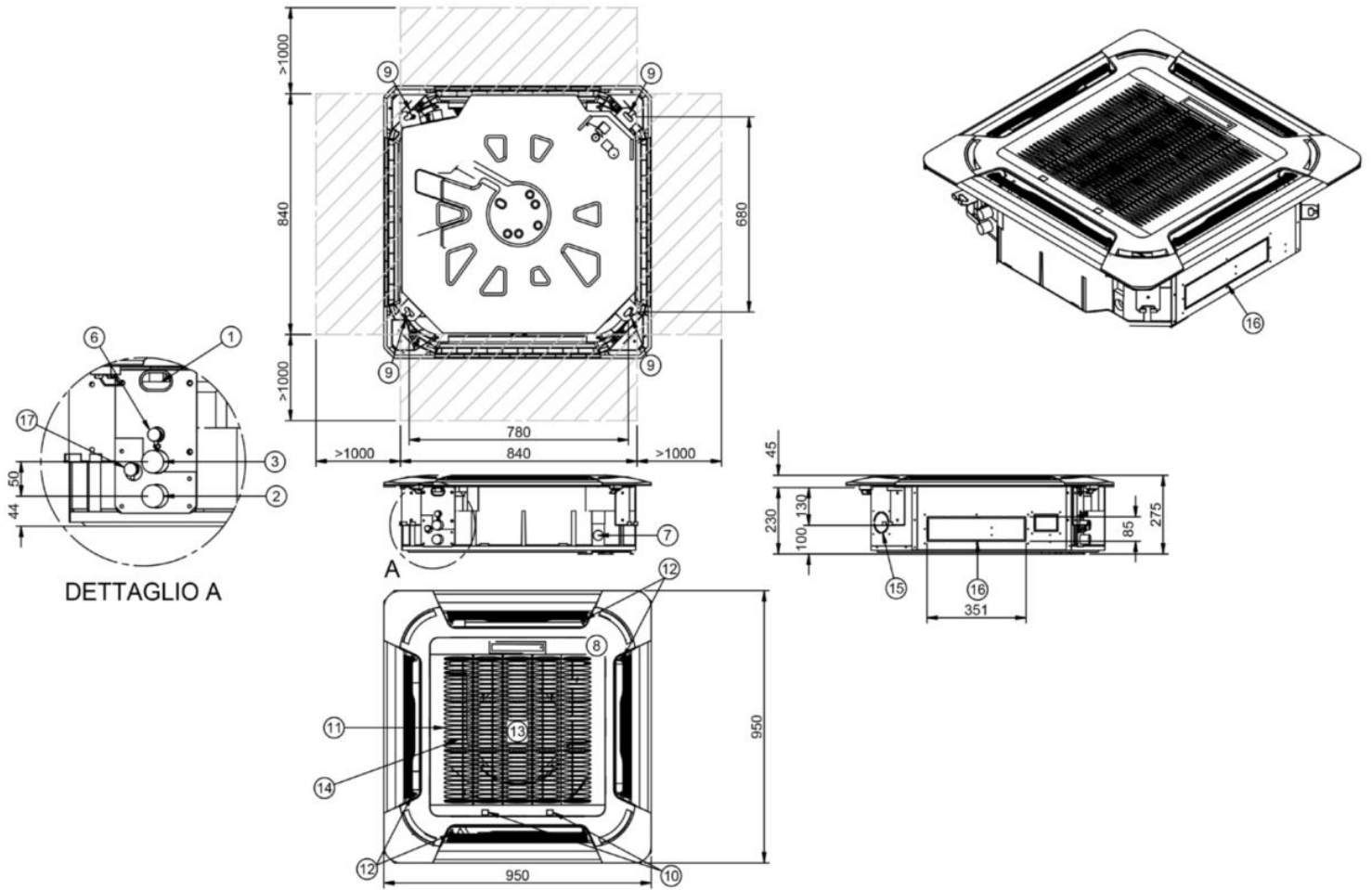

- 1. Power input
- 2. Water outlet (standard unit) Ø3/4"
- 3. Water inlet (standard unit) Ø3/4"
- 6. Water bleeds
- 7. Condensate drain by pump Ø32
- 8. Electrical panel
- 9. Suspension brackets
- 10. Filter access lugs

- 11. Return air inlet
- 12. Air flaps
- 13. Fan
- 14. Filter
- 15. Fresh air spigot Ø75mm
- 16. Branch duct spigot
- 17. Air discharge